

AxM® - ISTRUZIONI DI MONTAGGIO DEL SISTEMA BLOCCAGGIO SU BARRA DIN

AxM® - ASSEMBLY INSTRUCTION FOR DIN BAR LOCKING SYSTEM

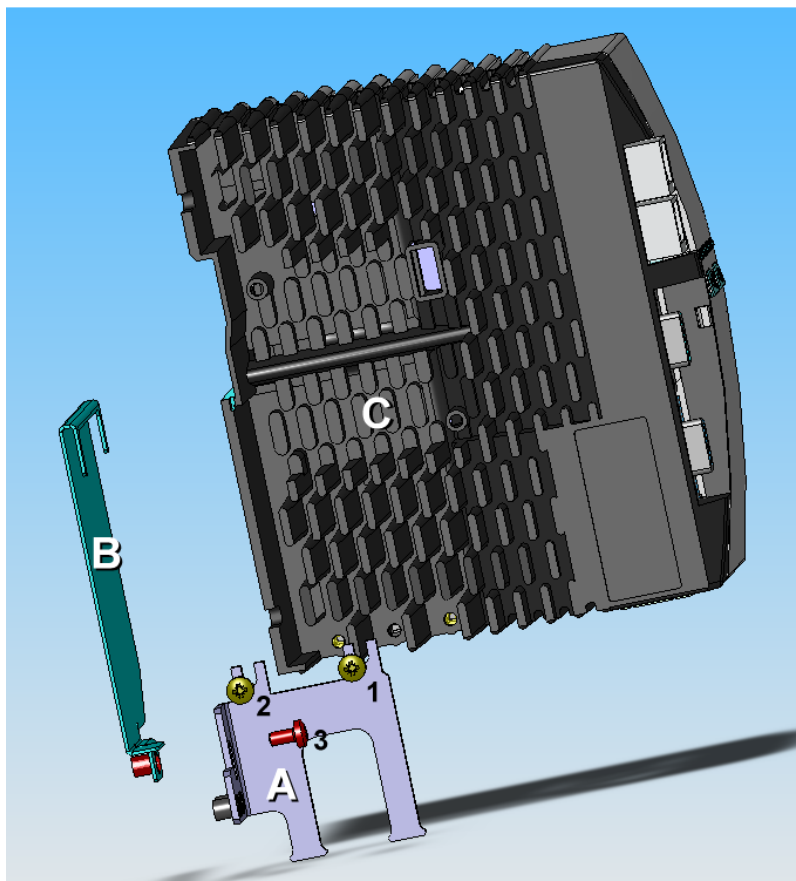
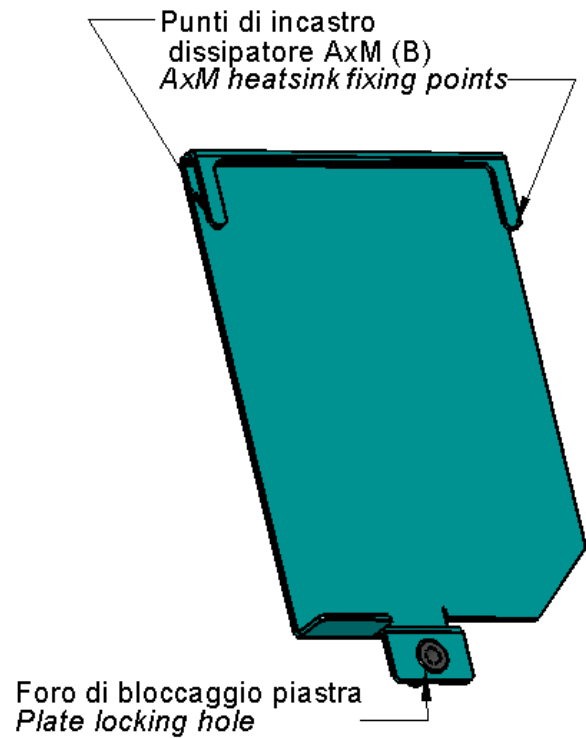
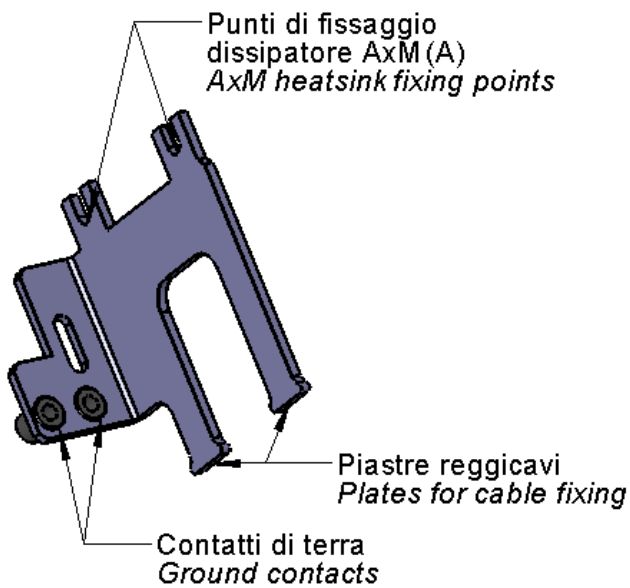

- 1) Montare la piastra reggicavi A sul dissipatore C tramite le viti 1 e 2

Fix part A on heatsink C with screws 1 and 2

- 2) Montare la staffa di fissaggio B sul dissipatore C, incastrando le due linguette ripiegate nelle apposite asole

Fix part B on heatsink C, inserting the two bended tongues on relative windows

- 3) Bloccare le due piastre A e B con la vite 3 (Senza serrare completamente)

Lock parts A and B with screw 3 (without fully tighten)

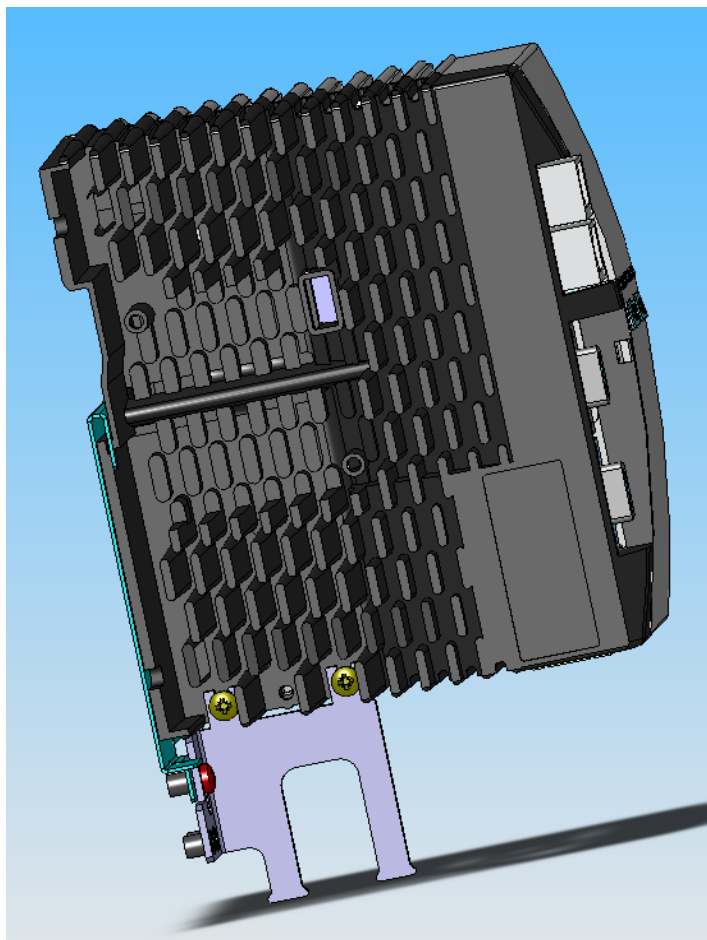

Per bloccare l'azionamento AxM®, incastrare il dissipatore sulla barra DIN , quindi portare la staffa (B) in posizione "chiuso" e serrare la vite 3

To lock AxM® drive fix heatsink C on DIN bar, then move part B on "locked position" and fully tighten screw 3

POSIZIONE APERTA
OPEN POSITION

POSIZIONE CHIUSA
LOCKED POSITION

