

Type	A (mm)
U316H090	600
U316H120	720

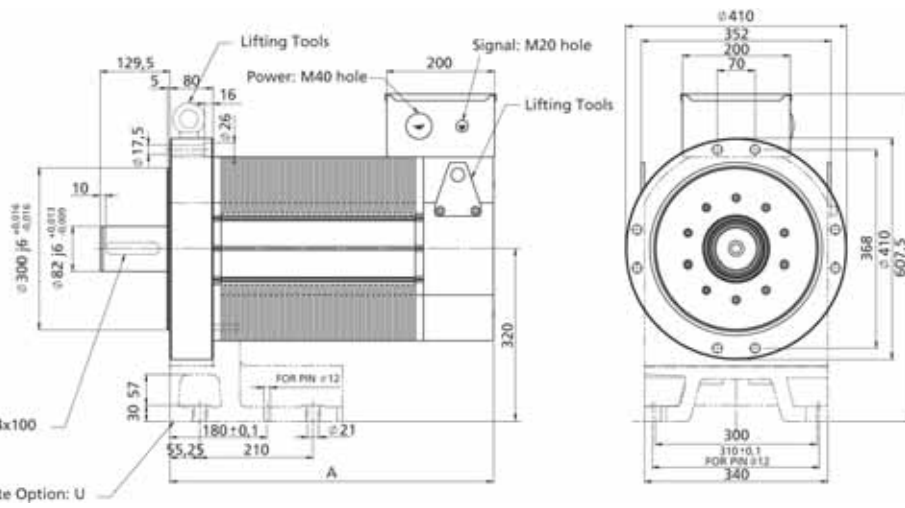

Forelock 22x14x100
Option: K

Baseplate Option: U



Curve delle prestazioni

Safe operating areas

16H

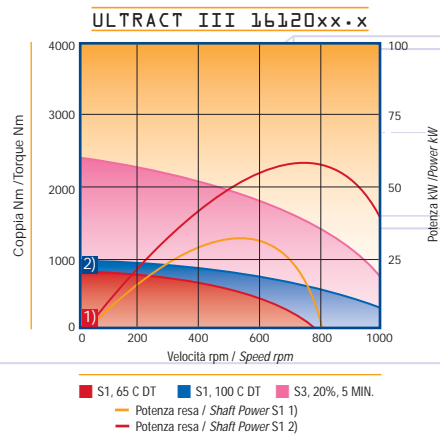
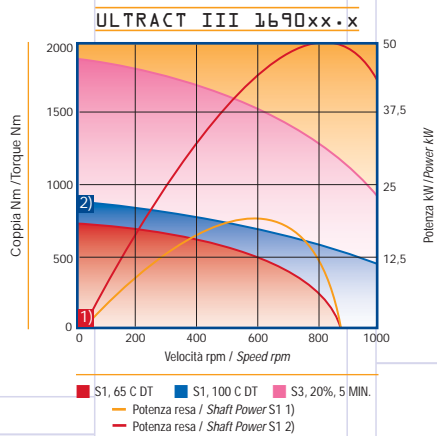

UL III-16xxxx.x

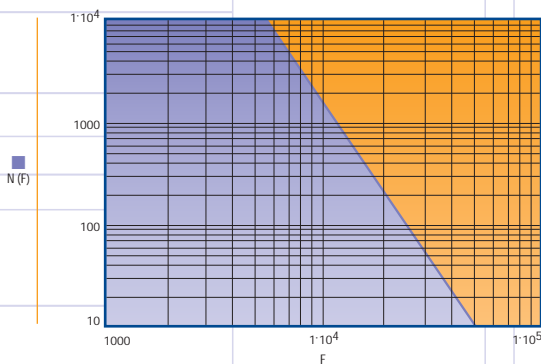

Vita (milioni di giri) dei cuscinetti in funzione del carico radiale (N) applicato alla mezziera della sporgenza d'albero del motore.
Bearing calculated lifetime (million of revs) versus radial load (N) applied in the middle of the shaft.

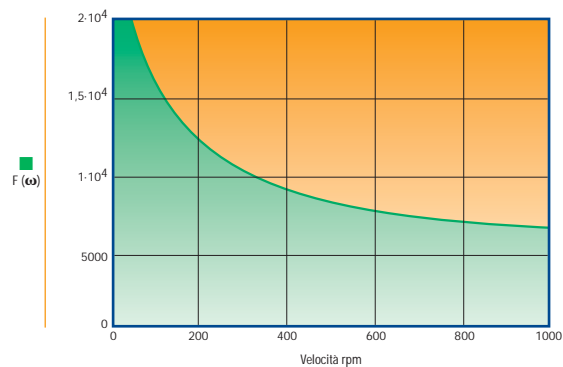

Massimo carico radiale (N) ammesso a metà dell'estensione albero, in funzione della velocità, riferito ad una vita di 30000 h. Il carico assiale non dovrebbe mai eccedere il 30% del carico radiale ammesso.
Max. radial load applicable in the middle of the shaft extension versus speed referred to 30000 h lifetime. Axial load should never exceed 30% of rated radial load.