

Type	D (mm)	A (mm)
1004x F	205	345
1007x F	280	420
1010x F	354	494
1013x F	429	569

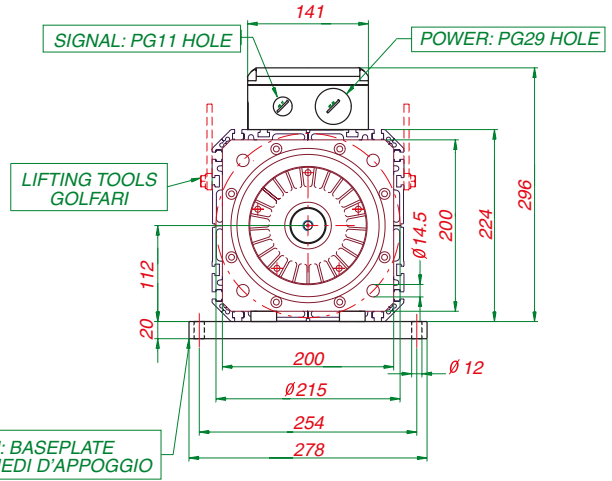
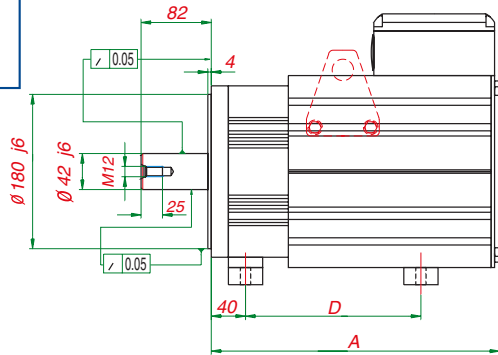

OPTION: BASEPLATE
OPZIONE: PIEDI D'APPOGGIO

Curve delle prestazioni

Safe operating areas

10F

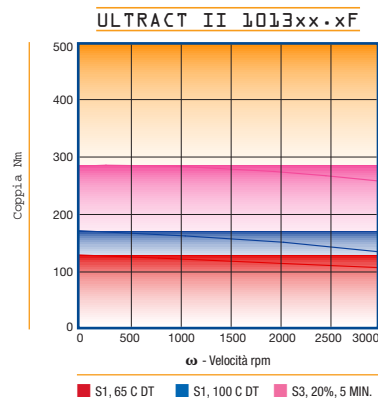
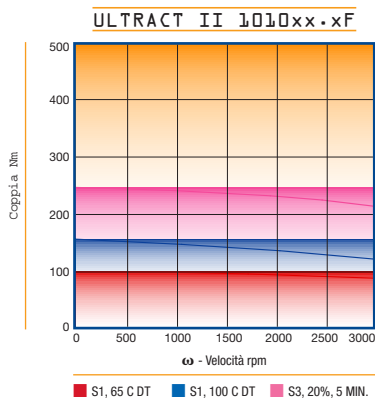
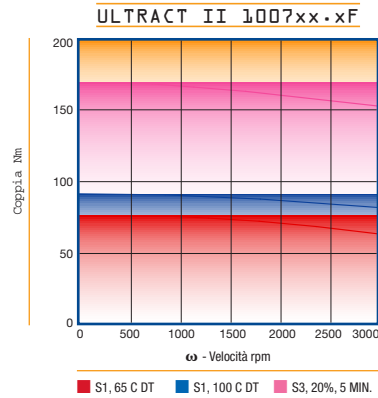
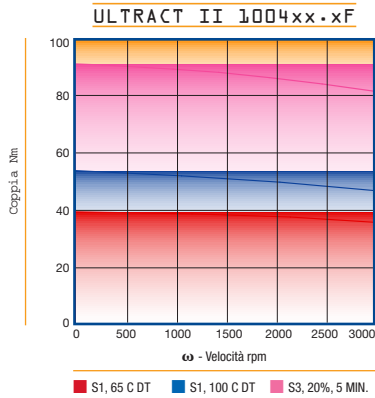

CUSCINETTI: come taglia 10 (BEARINGS: see size 10)

ALIMENTAZIONE VENTILATORE (FAN SUPPLY)

Tensione alimentazionef	380 ± 15%	VAC, 1 ∅
Fan voltage		
Corrente alimentazionef	0.2	Arms
Fan current		
Frequenzaf	50 - 60	Hz
Frequency		
Temperature di accensione f	80	°C
Temperature threshold		