

0.1 A  
Assembly dimension

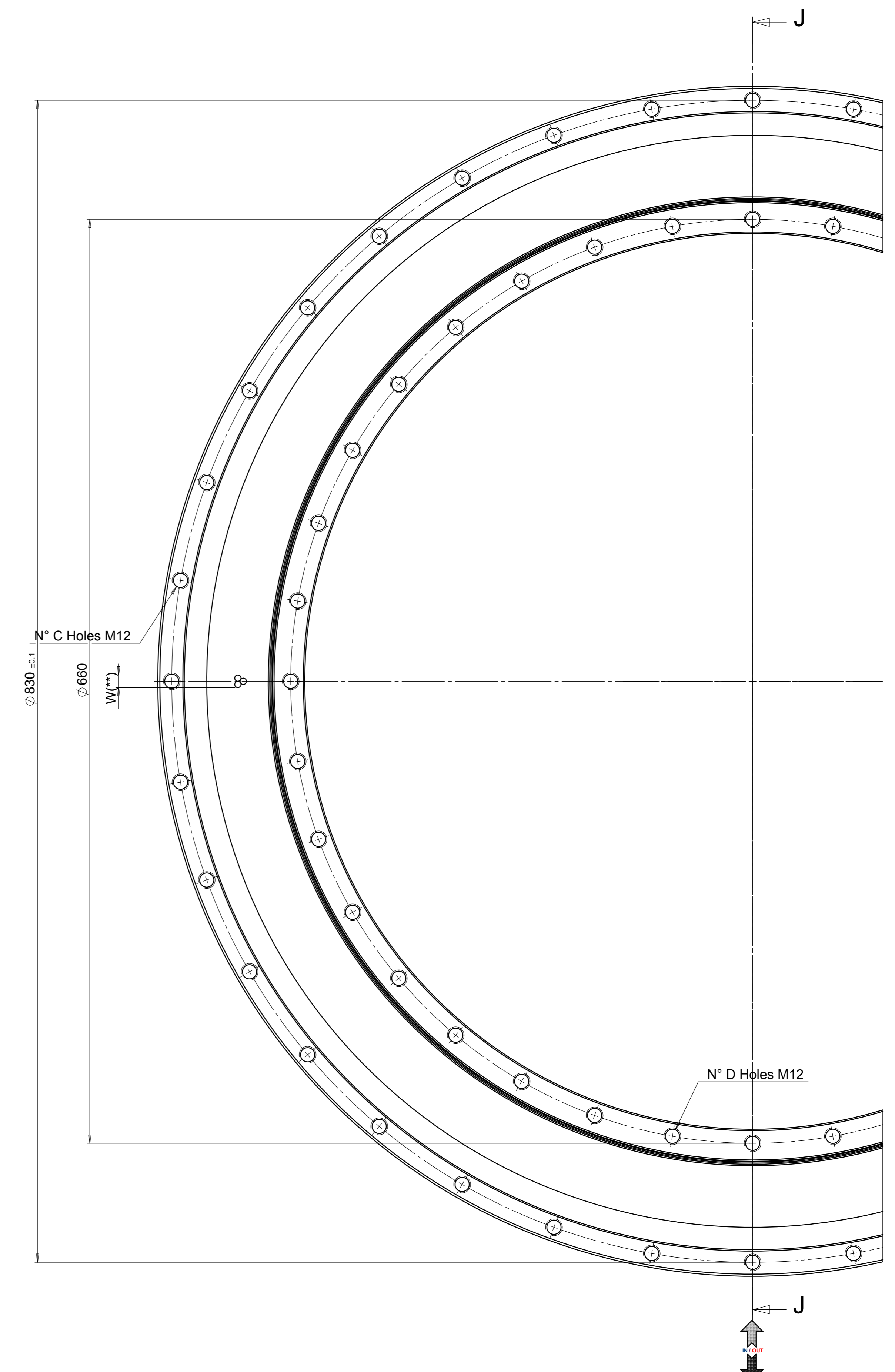

**CABLING**

To drive power output

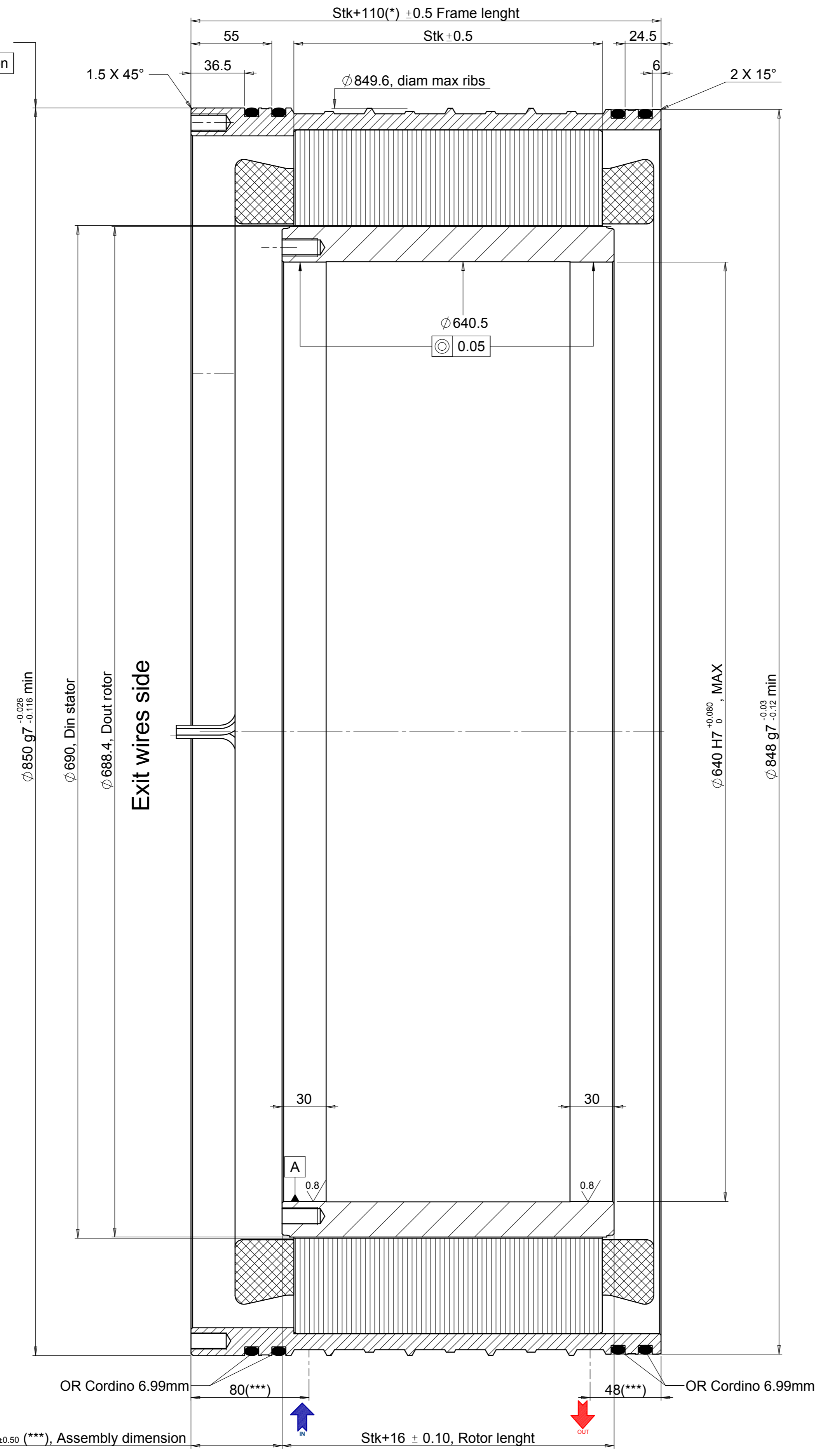
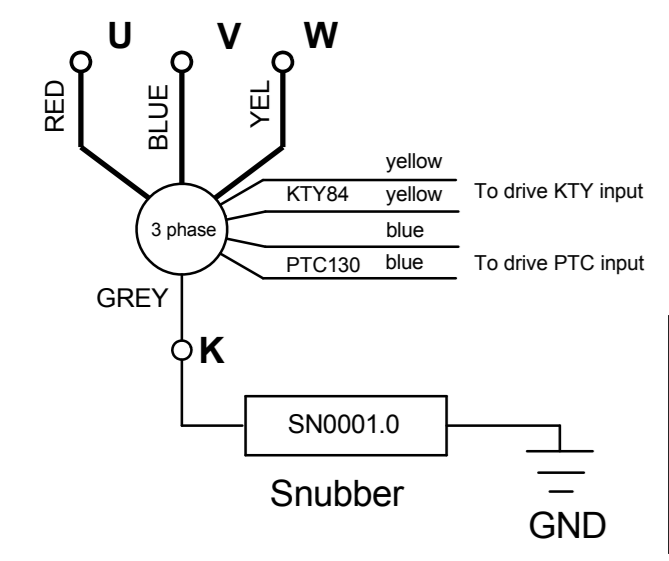

Wires Data	
Type Motor	TK 820-xxx-yy - Squid
Power Wires (U, V, W)	TEFZEL (**)mmq
Neutral Wire (K)	AWG 16
Sensor Wires	AWG 24
Length wires	1000 mm

**NOTE:** (\*) These dimension can be increased for low polarity motors and must be confirmed together with detailed datasheet definition  
 (\*\*) Dimensions dependent on the motor type: indicated in the data sheet.  
 General tolerances: geometrical tolerance (ISO 2768-2) class K  
 linear tolerance (ISO 2768-2) class m.  
 (\*\*\*) Suggested position for hydraulic connectors.

Type motor	Stk	C	D
TK 820-210-yy	210	36	36
TK XXX-XXX-yy	xxx	xxx	xxx

**Type:Squid Torque Motor**

04993-0-A-0 - TK 820-xxx-yy Squid motor

