

CABLING
To drive power output

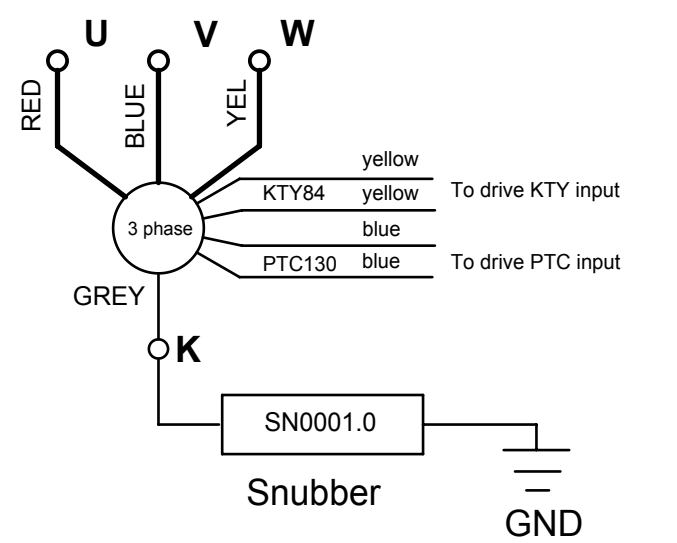

Wires Data	
Type Motor	TK 1150-xxx-yy - Squid
Power Wires (U, V, W)	TEZEL (**)*mmq
Neutral Wires (N)	AWG 16
Sensor Wires	AWG 24
Length wires	1000 mm

NOTE: (*) These dimension can be increased for low polarity motors, and must be confirmed together with detailed datasheet definition
()** Dimensions dependent on the motor type: indicated in the data sheet
 General tolerances: geometrical tolerance (ISO 2768-2) class K
 linear tolerance (ISO 2768-2) class m.
(*)** Suggested position for hydraulic connectors.

Type motor	Stk	C	D
TK 1150-250-yy	250	36	36
TK 1150-450-yy	450	60	60
TK XXX-XXX-YY	xxx	xxx	xxx

Type: Squid Torque Motor
04089-0-C-0 - TK 1150-xxx-yy Squid motor

